



Aquaculture

Safety, Reliability, Innovation



GUNNEBO
Industries

Our history, experience and quality

Gunnebo Industries was founded in 1764 in the small town of Gunnebo in the south of Sweden. In the very beginning the company forged nails and bolts for ship-making but quickly expanded to make chains and lifting products.

For every problem there is a solution, and through innovation Gunnebo Industries has established itself as a market leader in the lifting industry. We are very proud of our heritage, with a brand that has been built on its wealth of industry experience that is second to none. These attributes give both customer and distributor piece of mind with the range of products Gunnebo Industries provides.

We understand that safety is of utmost importance, not only for the users of our products, but for the environment as well, a fish pen breakage would have significant impact on both the environment and the business it was part of. It is of vital importance that the products used in the Aquaculture industry are manufactured to outperform the regulating standards. Gunnebo Industries have a range of chains, shackles and mooring bolts designed specifically for the Aquaculture industry. These products are manufactured to exacting demands which ensure an extended product life, which will decrease the need for maintenance and give you peace of mind in even the roughest weather conditions.

Gunnebo Industries is proudly part of The Crosby Group

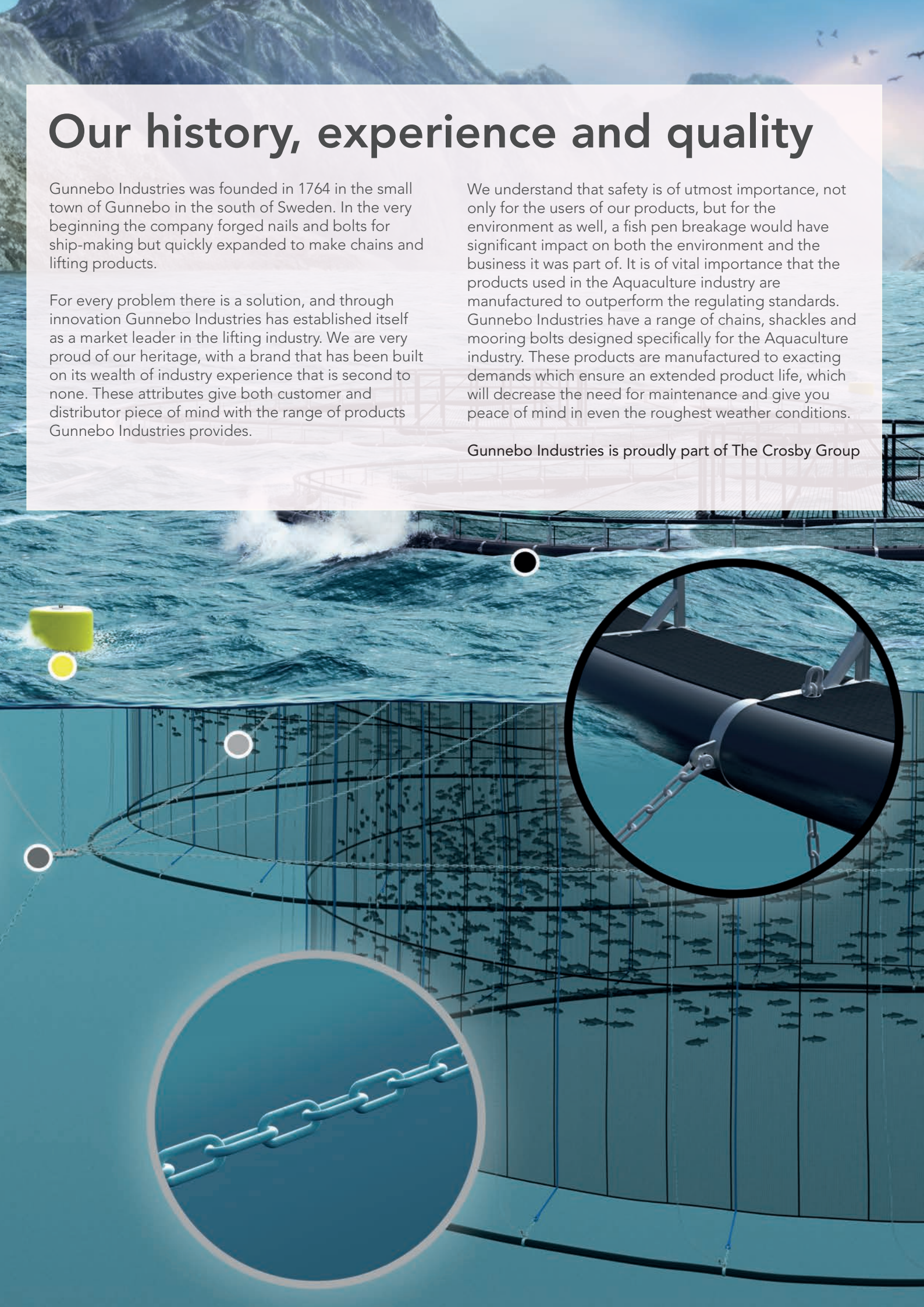

Feel confident in every situation

Our lifting systems are valued for their long durability and high quality. Whether the working environment is hot or cold, our systems assure lifting operations with high safety and functionality.

Gunnebo Industries shackles are made from a range of steel qualities, including acid proof stainless steel and high grade alloy steel to comply with the most stringent specifications. Our workshops comprise all facilities and systems for the manufacturing and control of a top quality product. This includes tool design, an advanced tool shop, forging, heat treatment, machining, hot dip galvanizing and quality control.

We offer a range of DNV 2.7-1 Type approved lifting shackles, developed for tough conditions, where safety must be of the highest priority at all times.

The heat treatment of these products ensures the proper ductility and strength to sustain shock loads which may be imposed when the container is lifted from the deck of a vessel.

Make sure you have the original

- High quality shackles according to EN 13889 and U.S. Fed. Spec RR-C. 271 (grade A and grade B)
- Consistent product quality
- Long experience of shackle production using modern manufacturing methods
- Local availability of expertise from Gunnebo Industries subsidiary or distributors

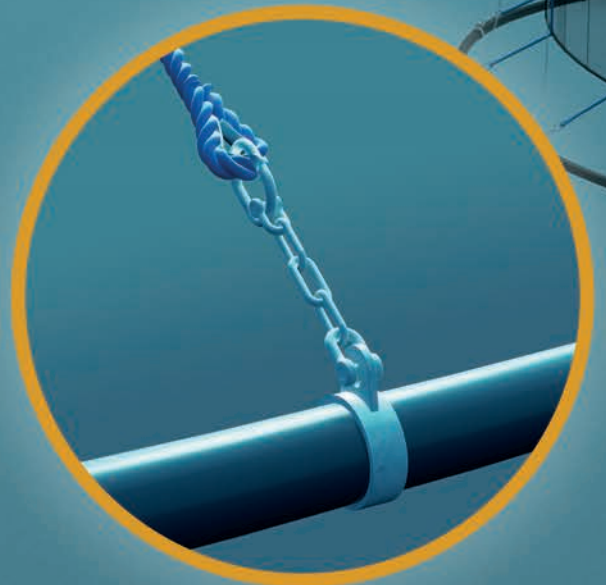
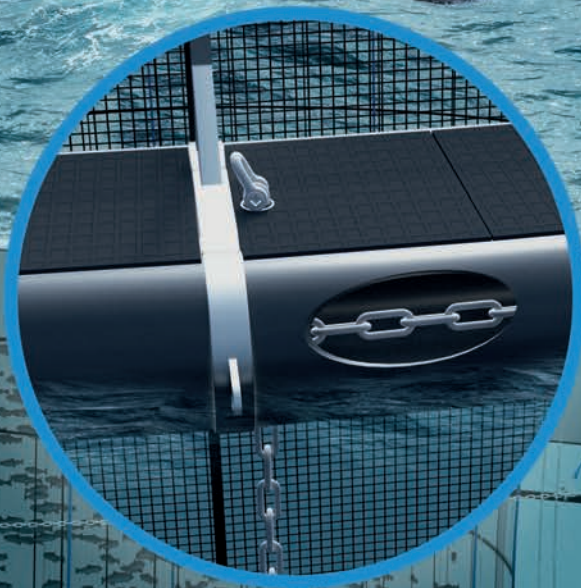



Aquaculture | Hot Dip Galvanized Chain

Adverse weather and rough sea conditions, coupled with the harsh marine environment must be taken into consideration when you specify the correct equipment for your aquaculture facilities. Our HDG chain is designed to meet the specific demands from the global aquaculture industry.

The chains are made from a premium high quality steel sourced from European steel producers to exacting standards and specifications. We have worked very closely with our material suppliers to ensure close and exacting standards are maintained throughout all production batches. These materials are then converted into chain at our own factory in Gunnebo, Sweden, where every component is 100% inspected during the manufacturing process.

Each element within the manufacturing process is stringently controlled with our in house quality systems; this also applies to our galvanizing and importantly our heat treating procedures which are critical factors in chain performance. To prevent the risk of unwanted stress levels, each chain link is subjected to heat treatment after calibration in order to reduce the in borne stress levels within it. Finally each chain link is visually inspected after calibration.

The ultimate corrosion protection process for steel components in the marine industry is hot dipped galvanizing, this is again controlled to recognized marine standards. Gunnebo Industries have been producing galvanized chains for more than 50 years.

Long Link Chain LLZ, Grade 6

Heat treatment

Quenched and tempered

Surface treatment

Hot Dip Galvanized (HDG)

Marking

GF

Not for lifting purposes.

Art. No	Code	Link dimensions			Min. breaking load (tonnes)	Weight kgs/m	Delivery length
		D nom.	P »	W1 »			
Z802207	LLZ-13-6	13	80	21.1	16.3	2.9	1 x 229,5 m
GS1073	LLZ-16-6	16	100	28	24.7	4.6	1 x 200 m
Z801458	LLZ-19-6	19	100	28,5	34.8	6.5	1 x 120 m
Z801887	LLZ-22-6	22	120	35	46.6	8.7	1 x 50 m
Z802447	LLZ-25-6	25	140	39	60.0	12.0	1 x 50 m
Z802449	LLZ-28-6	28	150	39	75.3	14.9	1 x 50 m
Z802451	LLZ-32-6	32	170	44	98.3	19.0	1 x 50 m

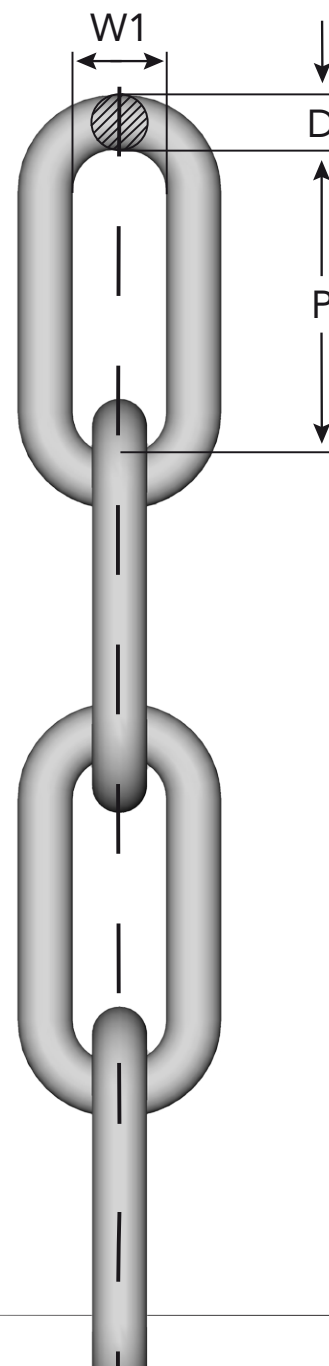

Corrosion protection by HDG

- More than 50 years of experience.
- Even and smooth surface results.

To prevent brittle fracture (reduced stress levels)

- Tension relieving process.
- A galvanizing process without acid pickling.

Quality

- In house production.
- Strict controls throughout the process.
- Third part type approval according to NS 9415.
- Visual inspection.



Aquaculture Mooring Shackle

Gunnebo Industries HDG shackles are designed to meet the specific demands from the global aquaculture industry. The shackles are produced from a grade of steel that has been developed to comply with the industry standards. Our modern manufacturing facilities in Norway are self-sufficient, from the initial tooling design and manufacture, through the component production facilities. All aspects of production are continually monitored at all stages: including forging, heat treatment, machining, hot dip galvanizing and final quality inspection. We have an extensive experience of shackle production using modern manufacturing methods.

Our Mooring shackle no. 852 has been developed specifically for the Aquaculture industry, with its unique

feature of a counter sunk bolt which locks the shackle, and with increased material thickness in the bow we have improved the fatigue resistance. With all our mooring shackles we are able to offer several securing options; standard or tailored. For many years our unique no. 852 mooring shackle has been used extensively in the Aquaculture industry.

Gunnebo Industries have improved this type of shackle through continuous improvement to satisfy the exacting demands of the Aquaculture industry. To fulfil one of these demands we have added countersunk shackle type A0830 to our portfolio of aquaculture products. We offer countersunk shackles both in Dee and Bow form.

Mooring Shackle No 852

Standard: Third party approved acc. to relevant Norwegian aquaculture standards

Material: High Tensile Steel. Quenched and Tempered, Grade 6

Finish: All parts hot dip galvanized + brown colour marking

Plastic clip provided as standard safety pin for 28T - 90T, Stainless steel A4 split pins provided as standard for 110T and 150T

Art.no	D Trade size		MBL (tonnes)	A	C	E	D2	D1
	mm	inch						
A085219	19	3/4"	28	44	100	58	48	22
A085222	22	7/8"	40	52	125	68	52	25
A085228	28	1 1/8"	60	62	150	89	64	28
A085232	32	1 1/4"	90	82	170	98	72	32
A085242	42	1 5/8"	110	112	200	150	90	45
A085244	45	1 3/4"	150	125	200	125	105	50

These sizes come with a sunken hexagon bolt head that will greatly reduce the risk of the bolt unscrewing during use as well as making the fitting easier for the user.

Customized securing options

- Plastic covered seizing wire
- Plastic covered steel wire
- Stainless steel cotter pin
- Clips (28T to 40T) – Yellow
- Clips (60T to 90 T) – Green

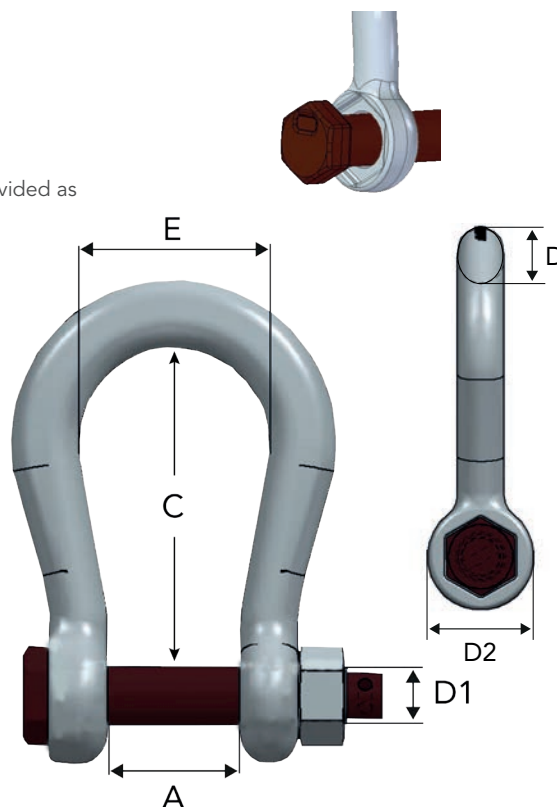

Mooring shackle No. 852

- Sunken bolt locks into the shackle to prevent rotation (unintentional loosening of the nut).
- The sunken bolt also reduces the risk of the shackle interacting with the net.
- Fatigue resistance is increased by the addition of 25% extra material in the bow (increased life span and safety).
- Spacious bow for connecting thimbles, rope and mooring/connecting plates.
- Easy to operate; Only one tool needed to assemble/disassemble.
- Hot dip galvanized pins (normally zinc plated) C/W grade 8 nuts.

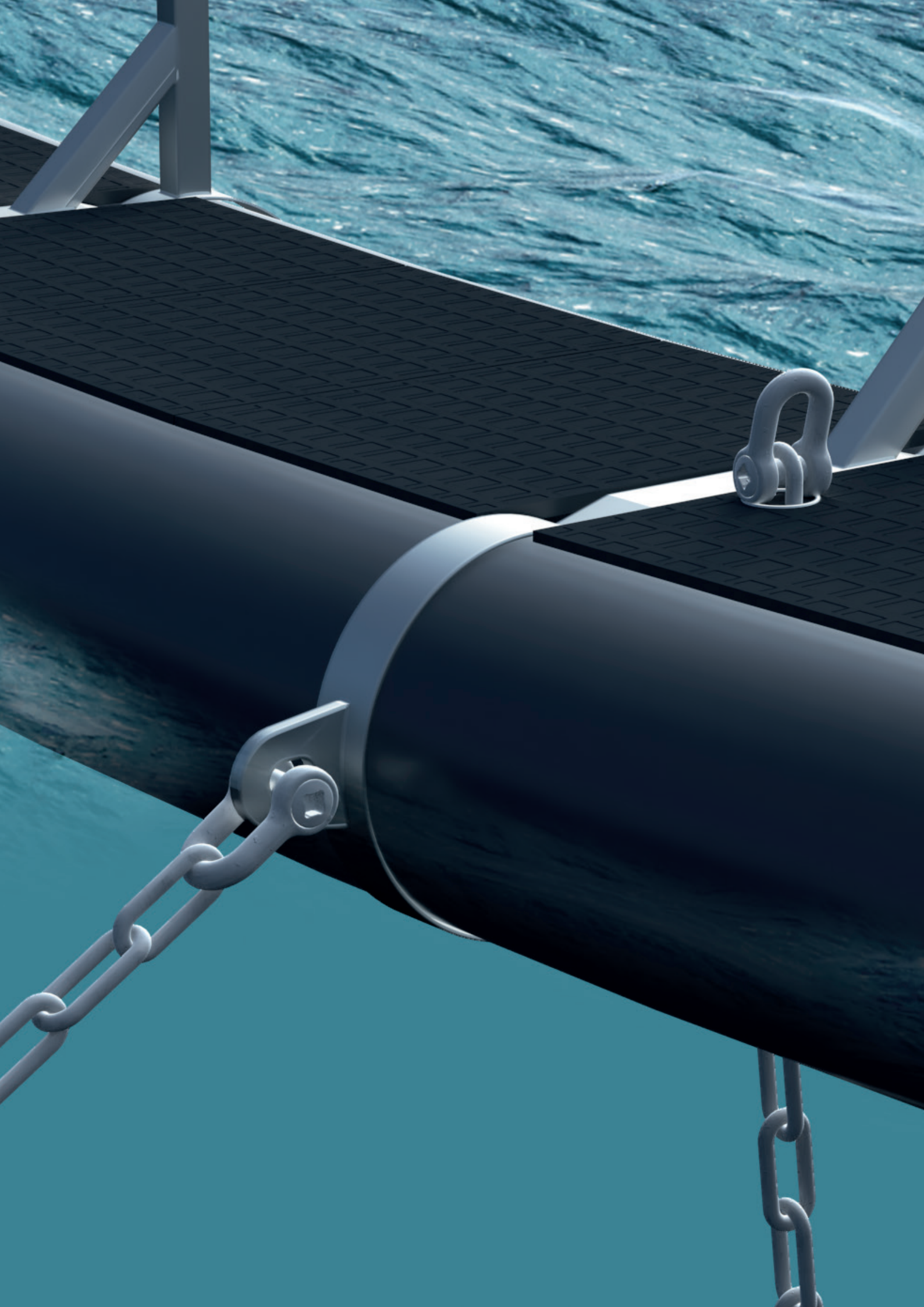

Countersunk Shackle - Bow & Dee

Gunnebo Industries shackles are made from close tolerance high tensile steel and are quenched and tempered to comply with the most stringent specifications. All parts are hot dip galvanized and have a brown coat applied to the pin on top of the zinc layer.

- Countersunk hole ensures easy/good tightening.
- No risk to fowling the nets - No protruding parts.
- Connecting (between two chain links) shackle for chain.
- Shackle bolt to fit direct into ratchet, no extra tools or collets needed.
- 3rd party approved to acc. **NS 9415**.
- Hot dip galvanized pins (normally zinc plated).
- High quality HDG applied through stringent quality control.

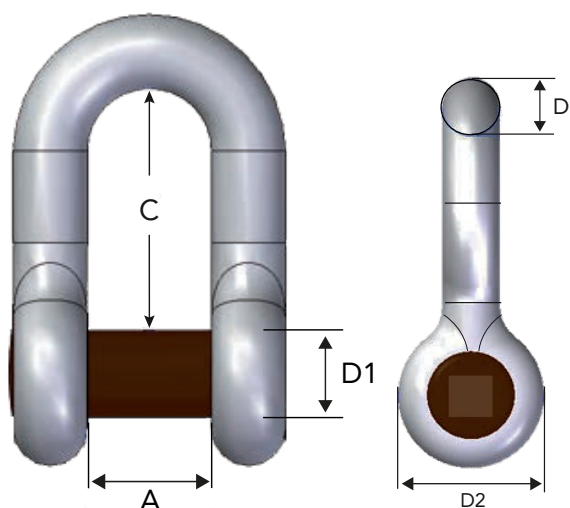

Countersunk Dee Shackle No A0830

Standard: Dimensions acc. to EN 13889

Material: High Tensile Steel. Quenched and Tempered, Grade 6

Finish: All parts hot dip galvanized + brown colour marking

Art.no	WLL (tonnes)	Dim. d (inch - mm)	D1	D	A	C	D2
A083013	2	1/2" - 13	16	1/2"	21	41	33
A083016	3.25	5/8" - 16	19	5/8"	27	51	40
A083019	4.75	3/4" - 19	22	3/4"	31	60	48
A083022	6.5	7/8" - 22	25	7/8"	37	71	52
A083025	8.5	1" - 25	28	1"	43	81	60

Countersunk Dee Shackles can also be supplied with a secondary securing for Double Protection (DP); A0830DP. Norwegian standard **NS9415** require secondary securing (Double Protection) on shackles used in mooring applications.

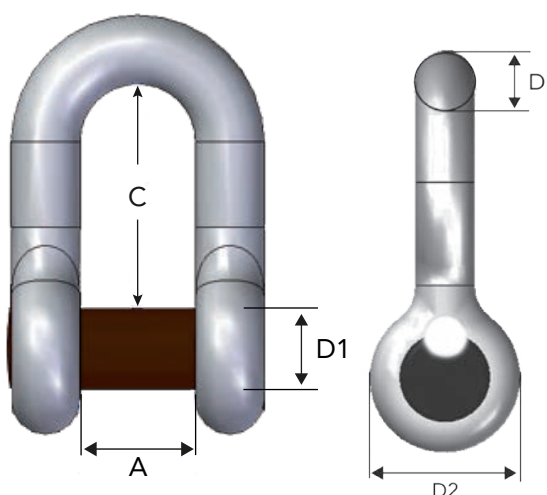

Countersunk Dee Shackle No A0830DP

Standard: Dimensions acc. to EN 13889. Third party approved acc. to relevant Norwegian aquaculture standards (NS 9415).

Material: High Tensile Steel. Quenched and Tempered, Grade 6

Finish: All parts hot dip galvanized and a Double Protection plug in non-corrosion material

Art.no	WLL (tonnes)	Dim. d (inch - mm)	D1	D	A	C	D2
A083013DP	2	1/2" - 13	16	1/2"	21	41	33
A083016DP	3.25	5/8" - 16	19	5/8"	27	51	40
A083019DP	4.75	3/4" - 19	22	3/4"	31	60	48
A083022DP	6.5	7/8" - 22	25	7/8"	37	71	52
A083025DP	8.5	1" - 25	28	1"	43	81	60

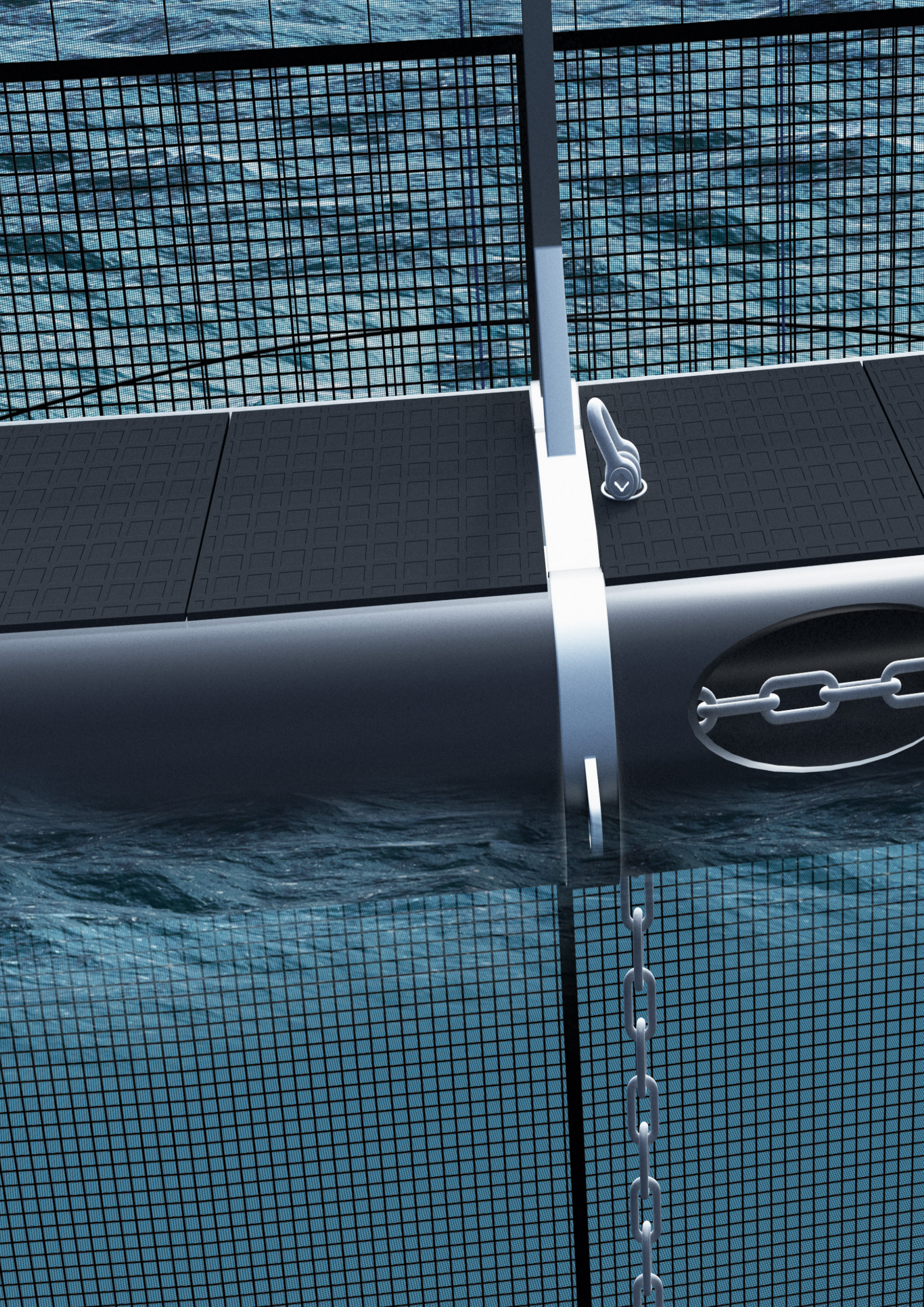

Aquaculture Countersunk Bow Shackle

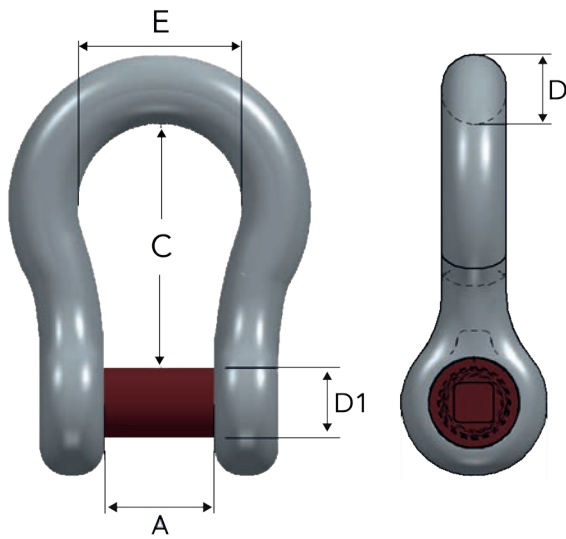

Countersunk Bow Shackle No A0850

Standard: Dimensions acc. to EN 13889

Material: High Tensile Steel. Quenched and Tempered, Grade 6

Finish: All parts hot dip galvanized + brown colour marking

Art.no	WLL (tonnes)	Dim. d (inch - mm)	D1	D	A	E	C	D2
A085013	2	1/2" - 13	16	1/2"	21	33	41	33
A085016	3.25	5/8" - 16	19	5/8"	27	40	51	40
A085019	4.75	3/4" - 19	22	3/4"	31	48	60	48
A085022	6.5	7/8" - 22	25	7/8"	37	52	71	52
A085025	8.5	1" - 25	28	1"	43	60	81	60

Countersunk Bow Shackles can also be supplied with a secondary securing for Double Protection (DP); A0850DP. Norwegian standard NS9415 require secondary securing (Double Protection) on shackles used in mooring applications.

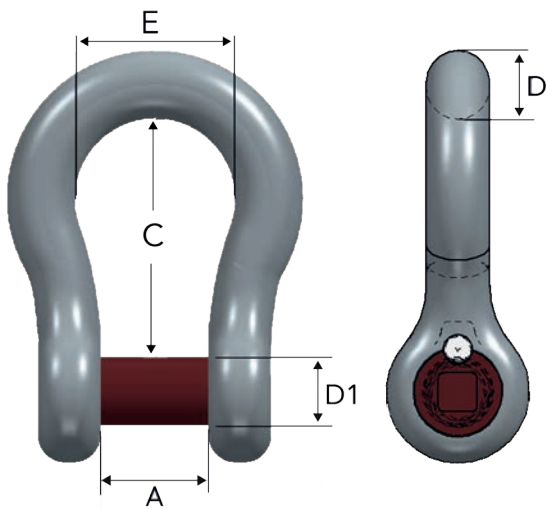

Countersunk Bow Shackle No A0850DP

Standard: Dimensions acc. to EN 13889. Third party approved acc. to relevant Norwegian aquaculture standards (NS 9415).

Material: High Tensile Steel. Quenched and Tempered, Grade 6

Finish: All parts hot dip galvanized and a Double Protection plug in non-corrosion material

Art.no	WLL (tonnes)	Dim. d (inch - mm)	D1	D	A	E	C	D2
A085013DP	2	1/2" - 13	16	1/2"	21	33	41	33
A085016DP	3.25	5/8" - 16	19	5/8"	27	40	51	40
A085019DP	4.75	3/4" - 19	22	3/4"	31	48	60	48
A085022DP	6.5	7/8" - 22	25	7/8"	37	52	71	52
A085025DP	8.5	1" - 25	28	1"	43	60	81	60

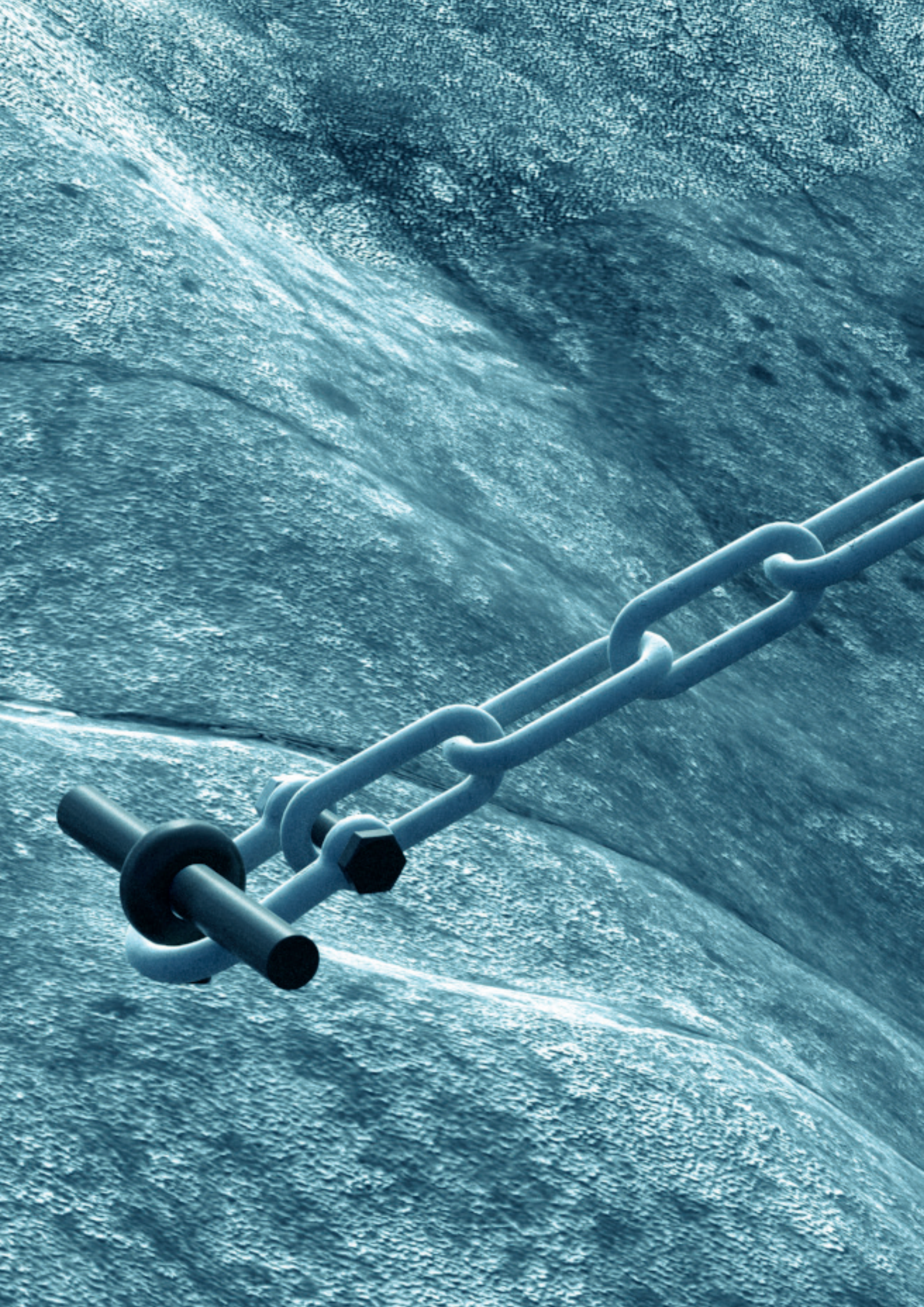

Mooring Bolt

Gunnebo Industries mooring bolts are made from high tensile steel and are quenched and tempered to comply with continuous monitoring and quality standards throughout manufacture. All parts are hot dip galvanized with a brown colour marking.

- Mooring bolts for both wedge and cement fastening applications.
- Bolts are marked with MBL and traceability code.
- Color marking showing required depth of fastening.
- Mooring bolts are 3rd part approved acc. to **NS 9415**.
- User instructions available.
- No A8252 – T-bolt flexible to secure straight/correct line direction.
- Certified according to **NS 9415** incl. 3.1 material information.
- All parts are high quality Hot Dip Galvanized.

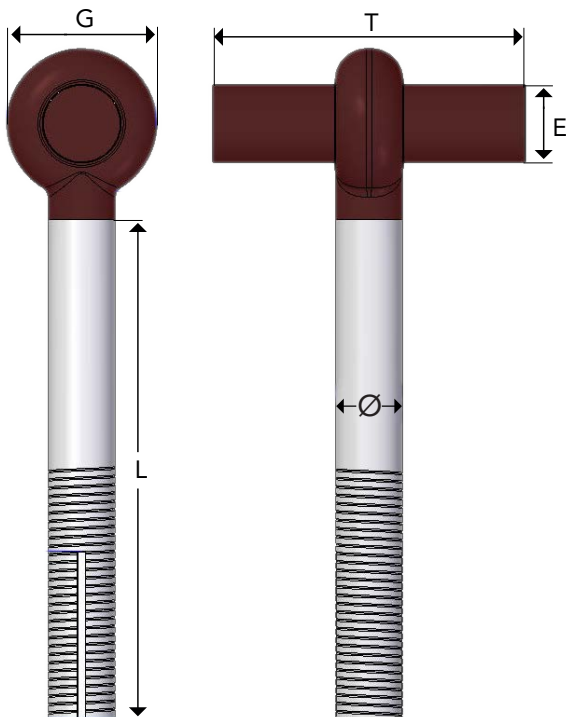

Mooring Bolt - T-bolt No 8252

Standard: Third party approved acc. to relevant Norwegian aquaculture standards (NS 9415)

Material: High Tensile Steel. Quenched and Tempered, Grade 6

Finish: All parts hot dip galvanized + brown colour marking

Art.no	Dim Ø x L	MBL tonnes	G	E	T
A825232	Ø32 x 400	40	72	35	300
A825238	Ø38 x 500	60	84	42	350
A825245	Ø45 x 600	80	105	45	400
A825250	Ø50 x 700	100	110	45	400
A825256	Ø56 x 800	130	127	50	400
A825265	Ø65 x 800	170	140	58	400

Additional length available on request.



Aquaculture | Hot Dip Galvanized Welded Chain Sling

Gunnebo Industries' chain slings are made from a specific material standard that has been proven to comply with the required industry standards. They are welded and galvanized at our chain factory in Gunnebo, Sweden. The chain and master links are produced under our own quality control standards. In-house production allows us to increase our flexibility regarding lengths and lead times. Our HDG process is highly valued in the aquaculture market for its smooth surface and high corrosion resistant.

NEW

- Flattened sections on the masterlink – make it quick and easy to fit thimbles.
- All parts are high quality Hot Dip Galvanized.
- 3rd party approval acc. to NS 9415.
- Short lead-time.
- Three components in one product – one inspection point – one certificate.
- High flexibility regarding lengths.
- No protruding parts.
- Available for LLZ- chain dimensions 13-22 mm.

Aquaculture | Galvanized Master Link

Our master link are made from a specific quality steel grade to comply with the most stringent of aquaculture standards. Our modern workshops in both Sweden and Norway are self-sufficient and are fully compliant with continuous monitoring of quality and performance at all stages of components production.

- Hot Dip Galvanizing is the industry standard for long term protection in the marine environment.
- Flattening bow to make it easy to put on thimbles.
- High quality HDG.
- 3rd party approved acc. to NS 9415.

Galvanized Master Link

Standard: Certified to Norwegian standard NS 9415
 Material: High Tensile Steel. Quenched and Tempered, Grade 6
 Finish: All parts hot dip galvanized

Art.no	dim Ø - D	MBL	B	L
A825922	Ø22	40 T	95	160
A825928	Ø28	60 T	110	190
A825934	Ø34	80 T	140	240
A825940	Ø40	110 T	150	250

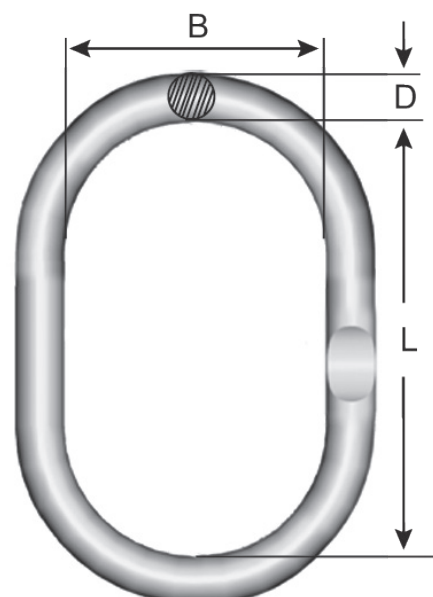



100

MBL 100T

MBL 60T

MBL 60T

MBL 60T

TXCP Connection Plate

Manufactured at our ISO9001 certified factory in the Netherlands, the TXCP uses the latest robotic welding machines to give an outstanding products.

- Fitted with zinc anodes as standard to reduce corrosion.
- Mounting holes make installation and inspection easier.
- Available in 3 sizes as standard to give the installer as much flexibility as possible during design and installation.
- High quality steel gives excellent metallurgical properties.
- The TXCP is fully galvanized for corrosion resistance.
- Certified to NS9415.

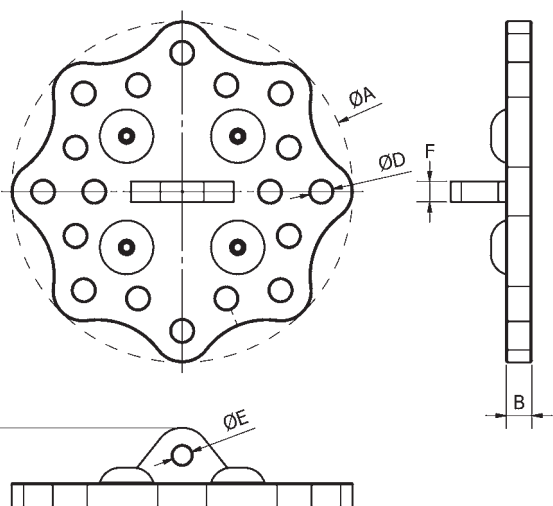

TXCP Connection Plate

Standard: Certified to NS9415

Material: High Tensile Steel

Finish: Hot dip galvanized

Art.no	MBL tonnes	Weight kg	Holes qty	Dimensions mm					
				A	B	C	D	E	F
2785700	50	28.5	8	410	30	138	36	37	30
2785709	100	56.5	12	527	40	148	39	37	40
2785759	100	72	16	572	40	148	39	37	40
2785718	150	114	16	680	50	158	46	37	40





Bow Shackle No 855

Gunnebo Industries shackles are made from close tolerance high tensile steel and are quenched and tempered to comply with the most stringent specifications. All parts are hot dip galvanized and have a brown coat applied to the pin on top of the zinc layer.

- Test certificate and traceable raw material/inspection according to EN-10204 -3.1. DNV 2.7-1 and DNV 2.7-3 Type Approval.
- Third party approved acc. to NS 9415

Bow Shackle No 855

Standard: DNV 2.7-1 type approved, EN-13889 and U.S. Fed. Spec. RR-C-271

Material: High Tensile Carbon Steel. Quenched and Tempered, Grade 6

Finish: All parts hot dip galvanized , brown painted bolts on top of galv.

Safety factor 6:1

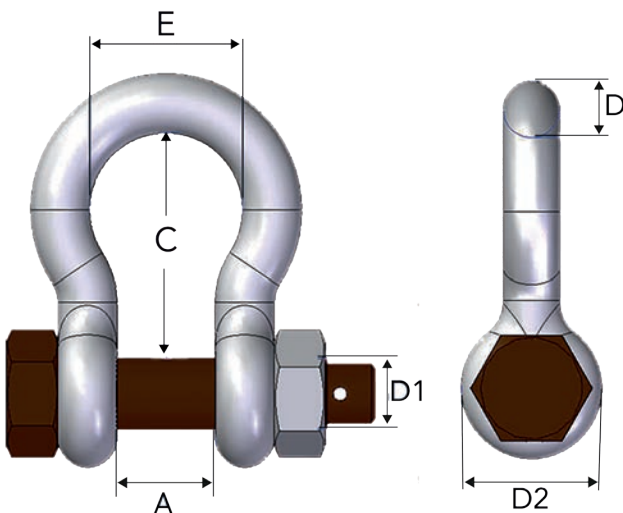

Art. no. Safety bolt	WLL tonnes 6:1	Dim. D1	D Trade size		inner width A*	inner length C*	Bow width E	Eye outer D2	Safety bolt kg
			mm	inch					
A085513	2.0	16	13	1/2"	21	47	33	33	0.42
A085516	3.25	19	16	5/8"	27	60	42	40	0.70
A085519	4.75	22	19	3/4"	31	71	49	48	1.20
A085522	6.5	25	22	7/8"	37	84	60	52	1.70
A085525	8.5	28	25	1"	43	95	68	60	2.58
A085528	9.5	32	28	1 1/8"	46	108	74	64	3.40
A085532	12.0	35	32	1 1/4"	52	119	83	72	4.80
A085535	13.5	38	35	1 3/8"	57	132	89	76	7.00
A085538	17.0	42	38	1 1/2"	60	146	98	84	9.00
A085545	25.0	50	45	1 3/4"	74	178	127	105	15.00

* Forging tolerance: +/- 5% on inside width/length.

Split pin included

theCrosbygroup®

The Crosby Group is a global leader in the innovation, manufacturing and distribution of products and services used to make lifting and load securement safer and more efficient, with premier brands such as Crosby, Gunnebo Industries, Straightpoint, Acco, McKissick, Trawlex, Lebus and CrosbyIP.

With global engineering, manufacturing, distribution and operations, the company provides a broad range of products and solutions for the most demanding applications with uncompromising quality that exceed industry standards.

The Crosby Group, with its team members around the world, provides an unparalleled training program supported by industry experience dating back hundreds of years, creating safer work environments for people everywhere.

thecrosbygroup.com

Part number 9992021

theCrosbygroup®

